

**SOT-23-6L 20/-20V 2N+2P Enhancement 增强型  
MOS Half Bridge 半桥**

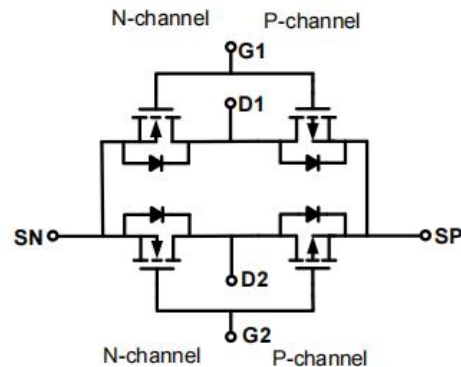
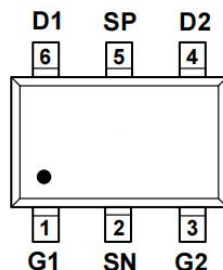

■ **Absolute Maximum Ratings 最大额定值**

Characteristic 特性参数	Symbol 符号	Rat 额定值	Unit 单位
Drain-Source Voltage 漏极-源极电压	$BV_{DSS}$	20/-20	V
Gate- Source Voltage 栅极-源极电压	$V_{GS}$	$\pm 10/\pm 10$	V
Drain Current (continuous)漏极电流-连续	$I_D$ (at $T_A = 25^\circ C$ )	3/-2	A
Drain Current (pulsed)漏极电流-脉冲	$I_{DM}$	10/-8	A
Total Device Dissipation 总耗散功率	$P_D$ (at $T_A = 25^\circ C$ )	700/700	mW
Thermal Resistance Junction-Ambient 热阻	$R_{\theta JA}$	178/178	$^\circ C/W$
Junction/Storage Temperature 结温/储存温度	$T_J, T_{stg}$	-55~150	$^\circ C$

■ **Device Marking 产品字标**

**FS6604B=6604B**

■ Electrical Characteristics 电特性(N)

( $T_A=25^{\circ}\text{C}$  unless otherwise noted 如无特殊说明, 温度为  $25^{\circ}\text{C}$ )

Characteristic 特性参数	Symbol 符号	Min 最小值	Typ 典型值	Max 最大值	Unit 单位
Drain-Source Breakdown Voltage 漏极-源极击穿电压( $I_D=250\mu\text{A}, V_{GS}=0\text{V}$ )	$BV_{DSS}$	20	—	—	V
Gate Threshold Voltage 栅极开启电压( $I_D=250\mu\text{A}, V_{GS}=V_{DS}$ )	$V_{GS(th)}$	0.55	0.78	1.1	V
Zero Gate Voltage Drain Current 零栅压漏极电流( $V_{GS}=0\text{V}, V_{DS}=20\text{V}$ )	$I_{DSS}$	—	—	1	$\mu\text{A}$
Gate Body Leakage 栅极漏电流( $V_{GS}=\pm 10\text{V}, V_{DS}=0\text{V}$ )	$I_{GSS}$	—	—	$\pm 100$	nA
Static Drain-Source On-State Resistance 静态漏源导通电阻( $I_D=3\text{A}, V_{GS}=4.5\text{V}$ ) ( $I_D=2\text{A}, V_{GS}=2.5\text{V}$ )	$R_{DS(ON)}$	—	40 55	52 80	$\text{m}\Omega$
Diode Forward Voltage Drop 内附二极管正向压降( $I_{SD}=3\text{A}, V_{GS}=0\text{V}$ )	$V_{SD}$	—	—	1.2	V
Input Capacitance 输入电容 ( $V_{GS}=0\text{V}, V_{DS}=10\text{V}, f=1\text{MHz}$ )	$C_{ISS}$	—	220	—	pF
Common Source Output Capacitance 共源输出电容( $V_{GS}=0\text{V}, V_{DS}=10\text{V}, f=1\text{MHz}$ )	$C_{OSS}$	—	34	—	pF
Reverse Transfer Capacitance 反馈电容( $V_{GS}=0\text{V}, V_{DS}=10\text{V}, f=1\text{MHz}$ )	$C_{RSS}$	—	26	—	pF
Total Gate Charge 栅极电荷密度 ( $V_{DS}=10\text{V}, I_D=3\text{A}, V_{GS}=4.5\text{V}$ )	$Q_g$	—	3.6	—	nC
Gate Source Charge 栅源电荷密度 ( $V_{DS}=10\text{V}, I_D=3\text{A}, V_{GS}=4.5\text{V}$ )	$Q_{gs}$	—	0.9	—	nC
Gate Drain Charge 栅漏电荷密度 ( $V_{DS}=10\text{V}, I_D=3\text{A}, V_{GS}=4.5\text{V}$ )	$Q_{gd}$	—	0.8	—	nC
Turn-ON Delay Time 开启延迟时间 ( $V_{DS}=10\text{V}, I_D=3\text{A}, R_{GEN}=3\Omega, V_{GS}=4.5\text{V}$ )	$t_{d(on)}$	—	8	—	ns
Turn-ON Rise Time 开启上升时间 ( $V_{DS}=10\text{V}, I_D=3\text{A}, R_{GEN}=3\Omega, V_{GS}=4.5\text{V}$ )	$t_r$	—	58	—	ns
Turn-OFF Delay Time 关断延迟时间 ( $V_{DS}=10\text{V}, I_D=3\text{A}, R_{GEN}=3\Omega, V_{GS}=4.5\text{V}$ )	$t_{d(off)}$	—	15	—	ns
Turn-OFF Fall Time 关断下降时间 ( $V_{DS}=10\text{V}, I_D=3\text{A}, R_{GEN}=3\Omega, V_{GS}=4.5\text{V}$ )	$t_f$	—	53	—	ns

■ **Electrical Characteristics 电特性(P)**

( $T_A=25^{\circ}\text{C}$  unless otherwise noted 如无特殊说明, 温度为  $25^{\circ}\text{C}$ )

Characteristic 特性参数	Symbol 符号	Min 最小值	Typ 典型值	Max 最大值	Unit 单位
Drain-Source Breakdown Voltage 漏极-源极击穿电压( $I_D = -250\mu\text{A}, V_{GS}=0\text{V}$ )	$BV_{DSS}$	-20	—	—	V
Gate Threshold Voltage 栅极开启电压( $I_D = -250\mu\text{A}, V_{GS}= V_{DS}$ )	$V_{GS(th)}$	-0.4	-0.62	-1	V
Zero Gate Voltage Drain Current 零栅压漏极电流( $V_{GS}=0\text{V}, V_{DS}= -20\text{V}$ )	$I_{DSS}$	—	—	-1	$\mu\text{A}$
Gate Body Leakage 栅极漏电流( $V_{GS}=\pm 12\text{V}, V_{DS}=0\text{V}$ )	$I_{GSS}$	—	—	$\pm 100$	nA
Static Drain-Source On-State Resistance 静态漏源导通电阻( $I_D = -2\text{A}, V_{GS}= -4.5\text{V}$ ) ( $I_D = -1.5\text{A}, V_{GS}= -2.5\text{V}$ )	$R_{DS(ON)}$	—	90 115	120 150	$\text{m}\Omega$
Diode Forward Voltage Drop 内附二极管正向压降( $I_{SD} = -2\text{A}, V_{GS}=0\text{V}$ )	$V_{SD}$	—	—	-1.2	V
Input Capacitance 输入电容 ( $V_{GS}=0\text{V}, V_{DS}= -10\text{V}, f=1\text{MHz}$ )	$C_{ISS}$	—	327	—	pF
Common Source Output Capacitance 共源输出电容( $V_{GS}=0\text{V}, V_{DS}= -10\text{V}, f=1\text{MHz}$ )	$C_{OSS}$	—	62	—	pF
Reverse Transfer Capacitance 反馈电容( $V_{GS}=0\text{V}, V_{DS}= -10\text{V}, f=1\text{MHz}$ )	$C_{RSS}$	—	55	—	pF
Total Gate Charge 栅极电荷密度 ( $V_{DS}= -10\text{V}, I_D = -2\text{A}, V_{GS}= -4.5\text{V}$ )	$Q_g$	—	4.5	—	nC
Gate Source Charge 栅源电荷密度 ( $V_{DS}= -10\text{V}, I_D = -2\text{A}, V_{GS}= -4.5\text{V}$ )	$Q_{gs}$	—	0.85	—	nC
Gate Drain Charge 栅漏电荷密度 ( $V_{DS}= -10\text{V}, I_D = -2\text{A}, V_{GS}= -4.5\text{V}$ )	$Q_{gd}$	—	1.4	—	nC
Turn-ON Delay Time 开启延迟时间 ( $V_{DS}= -10\text{V}, I_D = -1\text{A}, R_{GEN}=2.5\Omega, V_{GS}= -4.5\text{V}$ )	$t_{d(on)}$	—	6	—	ns
Turn-ON Rise Time 开启上升时间 ( $V_{DS}= -10\text{V}, I_D = -1\text{A}, R_{GEN}=2.5\Omega, V_{GS}= -4.5\text{V}$ )	$t_r$	—	30	—	ns
Turn-OFF Delay Time 关断延迟时间 ( $V_{DS}= -10\text{V}, I_D = -1\text{A}, R_{GEN}=2.5\Omega, V_{GS}= -4.5\text{V}$ )	$t_{d(off)}$	—	45	—	ns
Turn-OFF Fall Time 关断下降时间 ( $V_{DS}= -10\text{V}, I_D = -1\text{A}, R_{GEN}=2.5\Omega, V_{GS}= -4.5\text{V}$ )	$t_f$	—	46	—	ns

■ Typical Characteristic Curve 典型特性曲线(N)

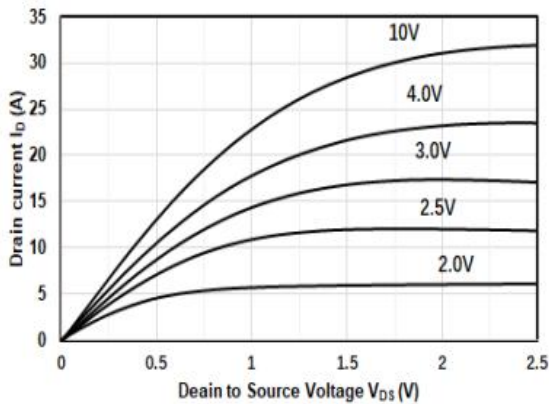

Figure 1: Output Characteristics

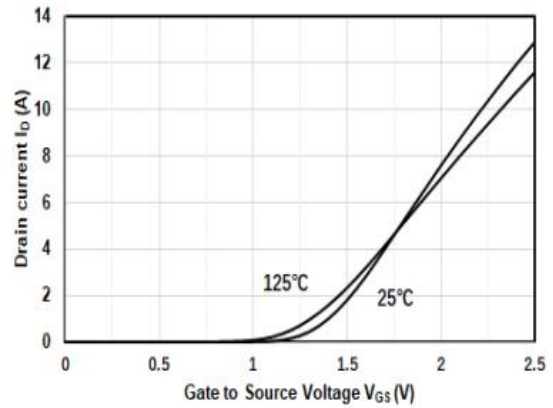

Figure 2: Transfer Characteristics

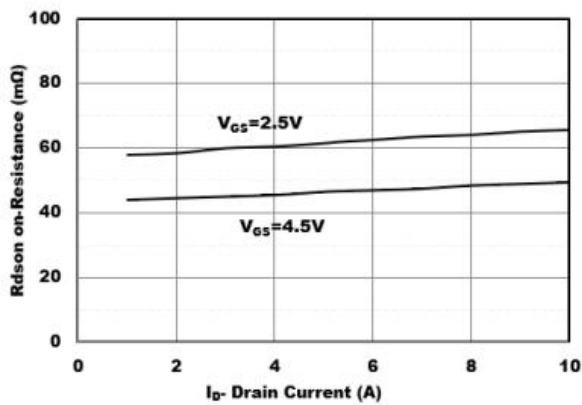

Figure 3: On-Resistance vs. Drain Current

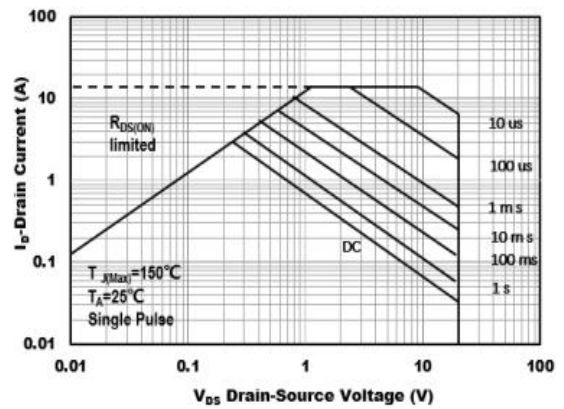

Figure 4: Safe Operating Area

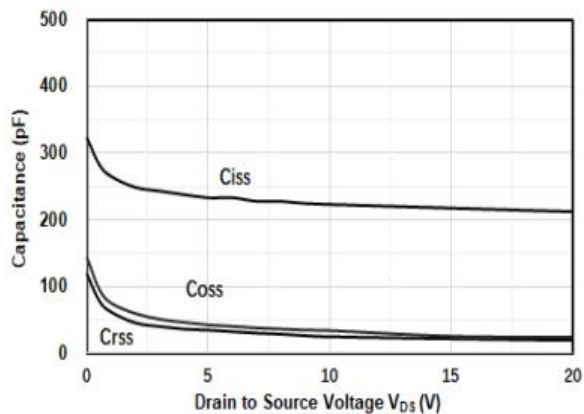

Figure 5: Capacitance Characteristics

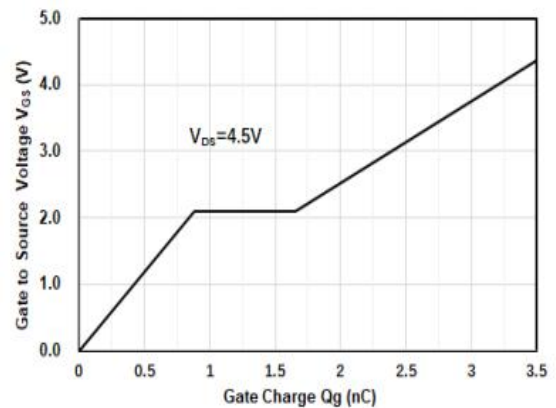

Figure 6: Gate-Charge Characteristics

■ Typical Characteristic Curve 典型特性曲线(P)

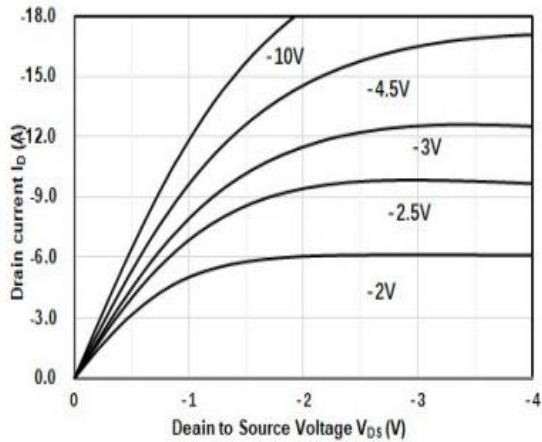

Figure 1: Output Characteristics

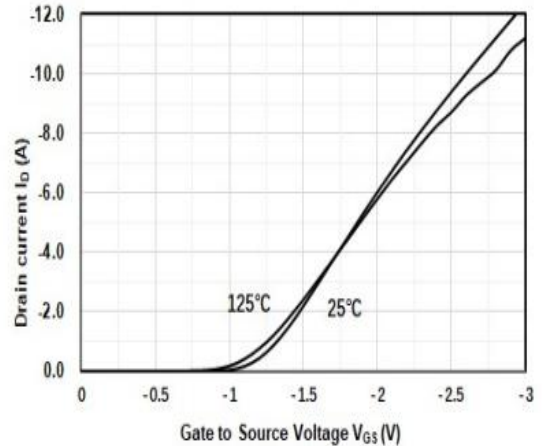

Figure 2: Transfer Characteristics

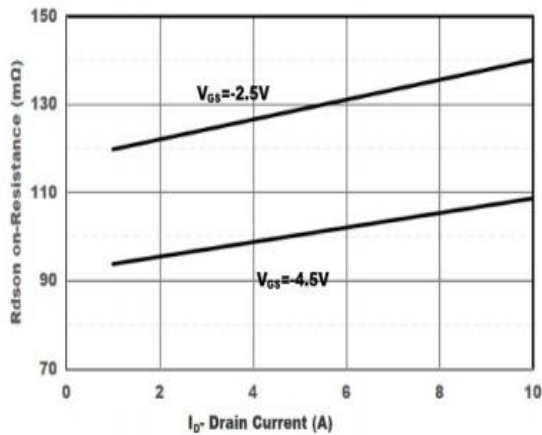

Figure 3: On-Resistance vs. Drain Current

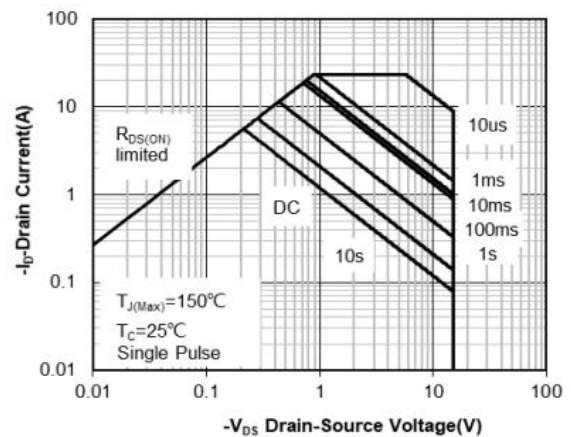

Figure 4: Safe Operating Area

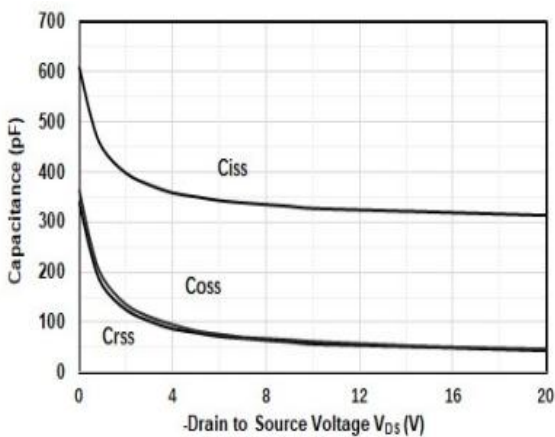

Figure 5: Capacitance Characteristics

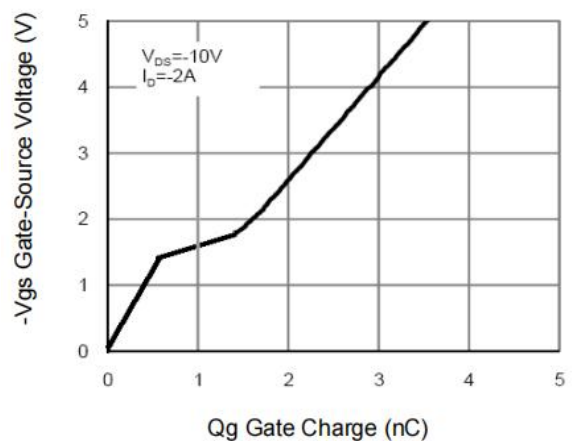
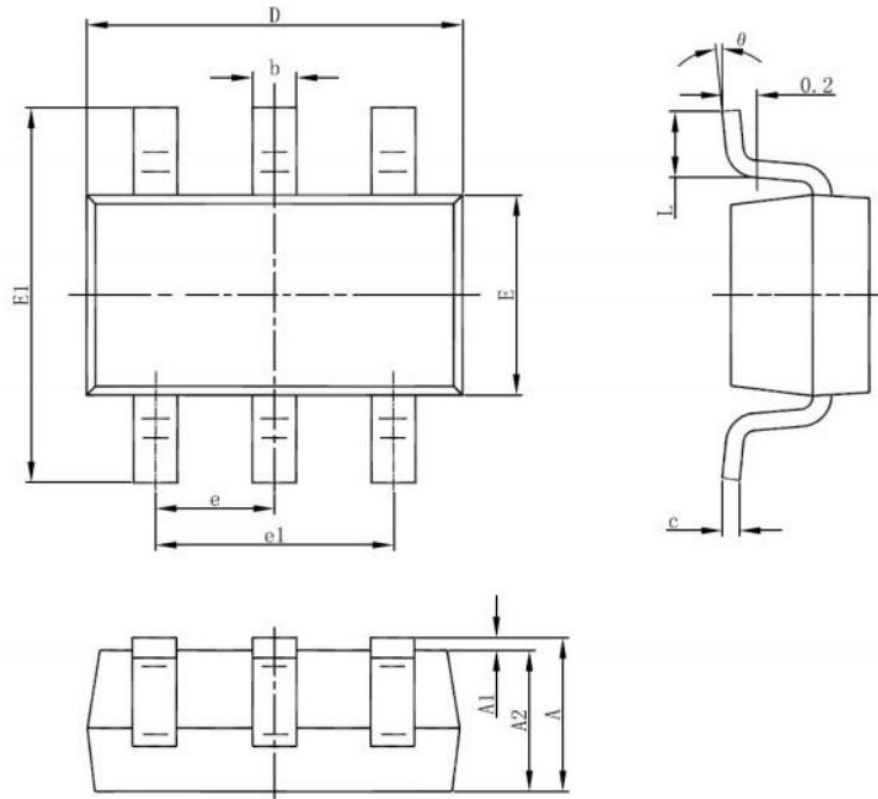

Figure 6: Gate-Charge Characteristics

■ Dimension 外形封装尺寸



Symbol	Dimensions In Millimeters		Dimensions In Inches	
	Min	Max	Min	Max
A	1.050	1.250	0.041	0.049
A1	0.000	0.100	0.000	0.004
A2	1.050	1.150	0.041	0.045
b	0.300	0.500	0.012	0.020
c	0.100	0.200	0.004	0.008
D	2.820	3.020	0.111	0.119
E	1.500	1.700	0.059	0.067
E1	2.650	2.950	0.104	0.116
e	0.900	1.00	0.035	0.039
e1	1.800	2.000	0.071	0.079
L	0.450	0.650	0.018	0.026
L1	0.300	0.600	0.012	0.024
$\theta$	0°	8°	0°	8°